

Resse 6636 Freestanding

67" x 36" x 24"

Acrylic Tub



DRAINS & OVERFLOW

- Overflow Integral Slot in Acrylic- No Trim
- Polished Chrome or Brushed Nickel
(Optional: White, Biscuit, Black, Polished Nickel or Oil Rubbed Bronze)

DECK MOUNT FAUCET OPTION

- Faucets not Included
- No Faucet Holes Drilled
- Access Panel Recommended (Option)

SYSTEM TUB FEATURES

- Quiet Anti-Vibration Pump Pad
- Hydro Cleanse
- Access Panel

Specifications and features are subject to change without notice and are +/- .25". All final measurements should be taken on site from the bathtub.



X Equipment Access Options

- Faucet Access (Optional)

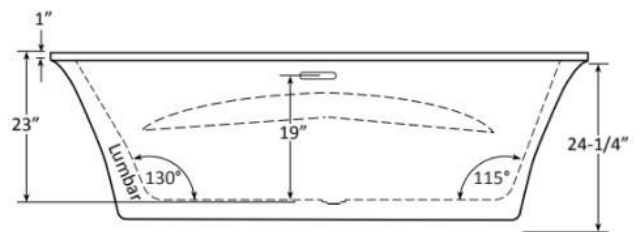
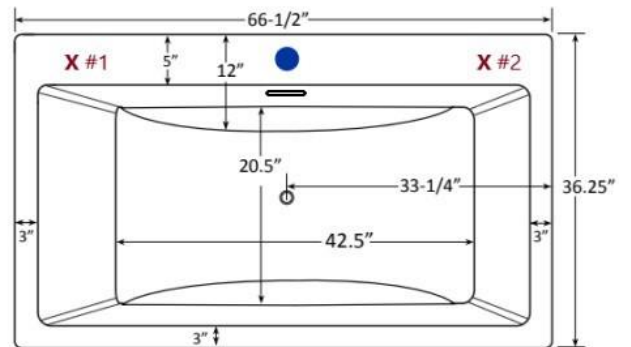

ACCESS

3" or more space is required to access the equipment panel. Tub may also need to be shifted or disconnected in some situations. Access panel equipment design and location may vary based on model.

JET LEGEND

- Back Jets
- Ultra Flow Jets
- 7 Port Jets
- 2 Jet Neck Pillow
- ↑ Inlet/Outlet
- Air Jets
- ▬ Grab Bar

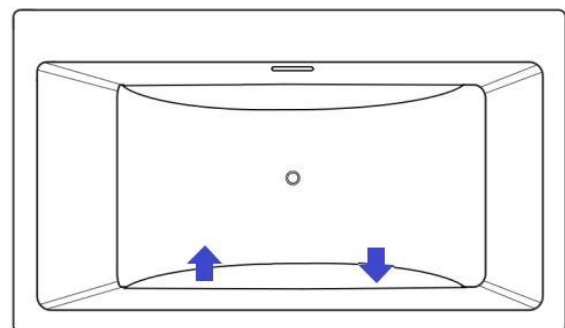

Heated Soaking

Micro Bubble

- (1) 115v 20AMP GFCI Circuit
- 1 Motor Access Location

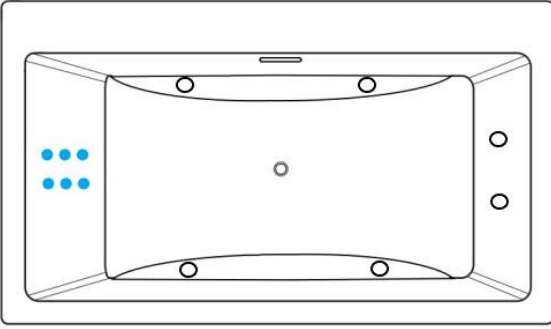

12 Jet Whirlpool
 (2) 115v 20AMP GFCI Circuits
 1 Motor Access Location

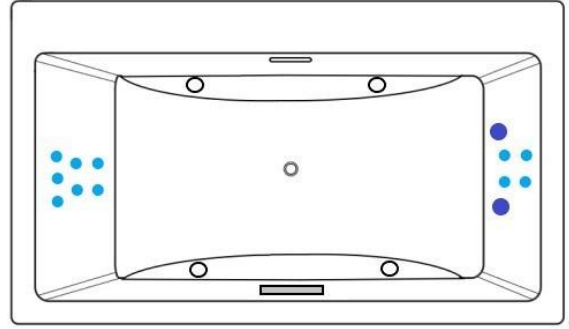

17 Jet Whirlpool
 (3) 115v 20AMP GFCI Circuits
 2 Motor Access Locations

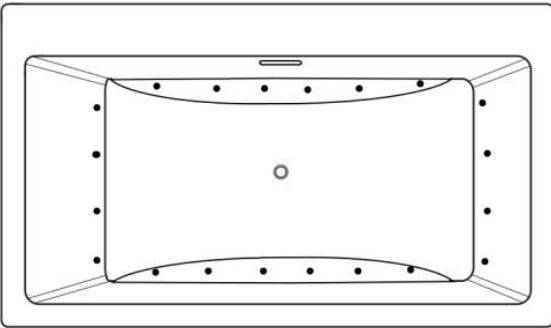

18 Jet Air Tub
 (1) 115v 20AMP GFCI Circuit
 1 Motor Access Location

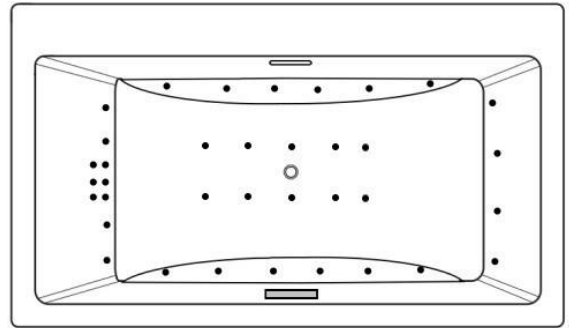

34 Jet Air Tub
 (2) 115v 20AMP GFCI Circuits
 2 Motor Access Locations

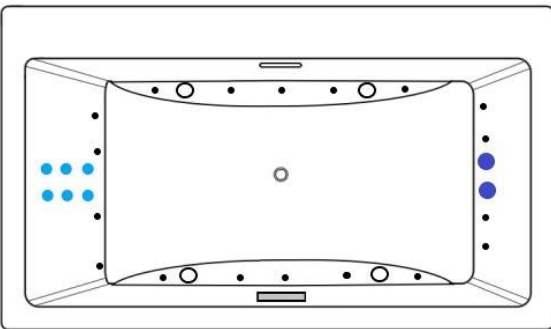

30 Jet Combination
 (3) 115v 20AMP GFCI Circuits
 2 Motor Access Locations

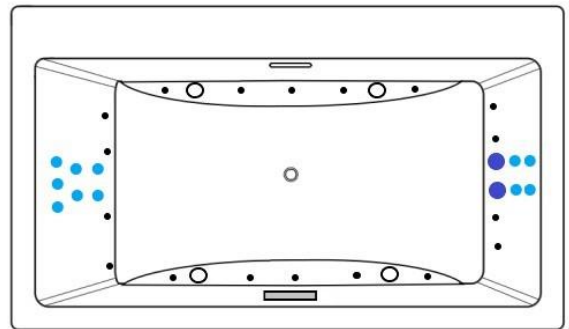

35 Jet Combination
 (3) 115v 20AMP GFCI Circuits
 2 Motor Access Locations

Jet & accessory locations are for demonstrative purposes only, not shown in the exact location.